

1. Principal parts

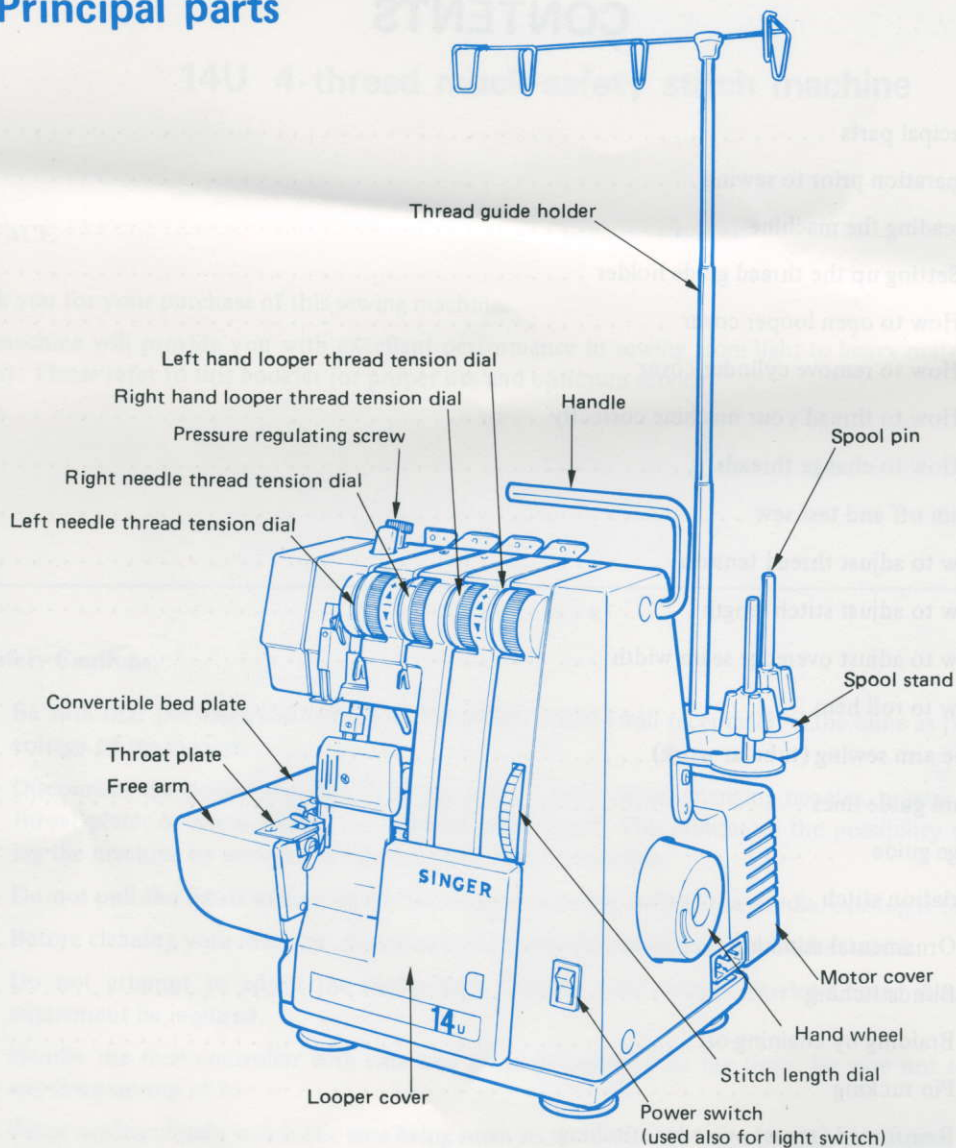

• Machine with looper cover opened

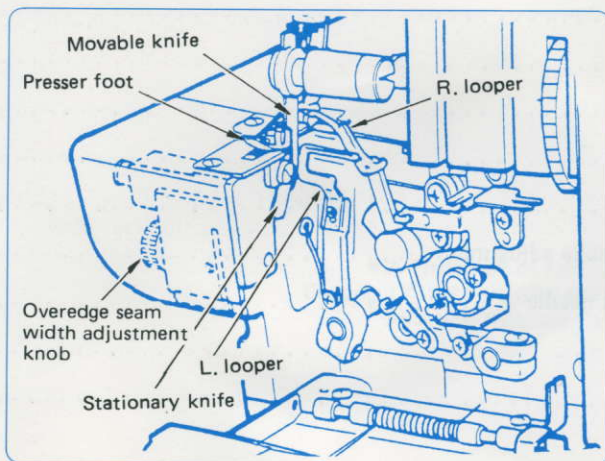

Gerrijts
 Handelsstraat 14
 9501 ET Stadskanaal
 tel. 0599-612419
www.naaimachinehandel.com
 en www.paspop.com
Info@gerrijts.nl

● How to open looper cover

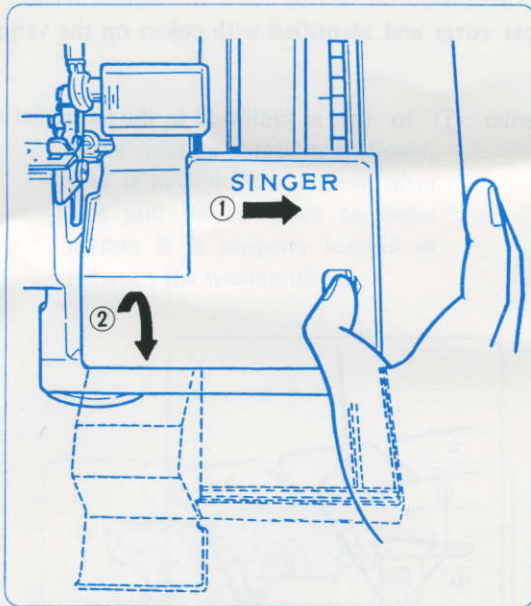

- ① Push the cover to the right as far as it will go and
- ② Pull cover down toward you.

* Be sure looper cover is closed when sewing.

● How to remove cylinder cover

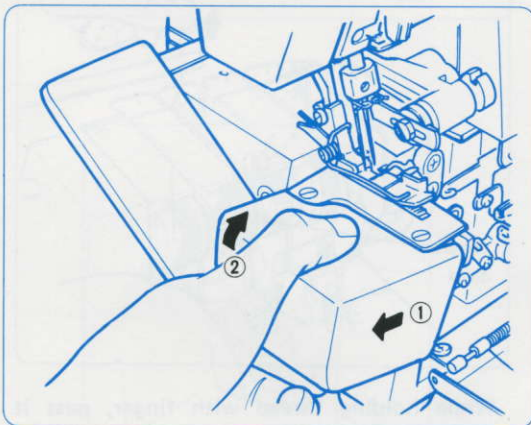

- ① While pulling the cylinder cover to the left,
- ② Lift cover upward and off the machine.

To replace cover

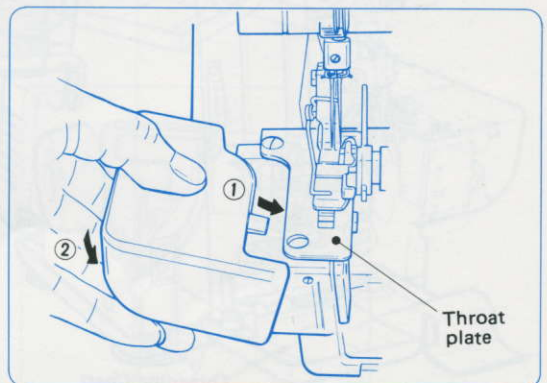

- ① Place tab on top of cover under the throat plate.
- ② Press cover downward to the right.

* Do not hold the cylinder cover when moving the machine.

● How to thread your machine correctly

Correct sewing cannot be obtained when machine is threaded incorrectly.

Threading is diagrammed on the inner side of the looper cover and identified with colors on the various thread guides.

- (1) Open looper cover. Thread the right looper in the order ① to ⑧ as indicated in the figure below. (threading points marked in orange)

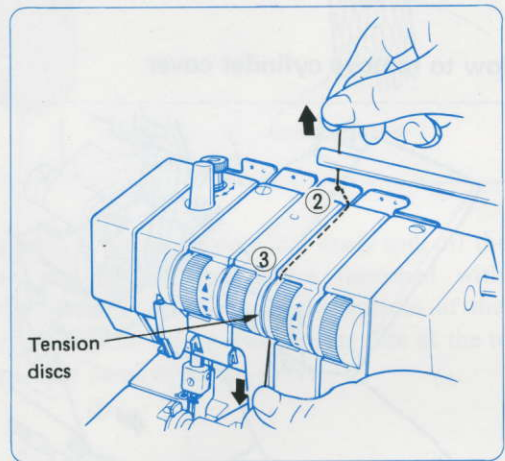
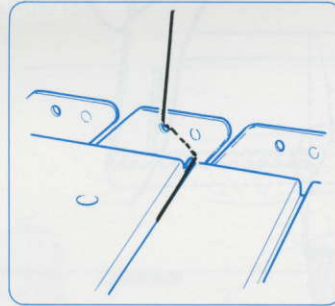
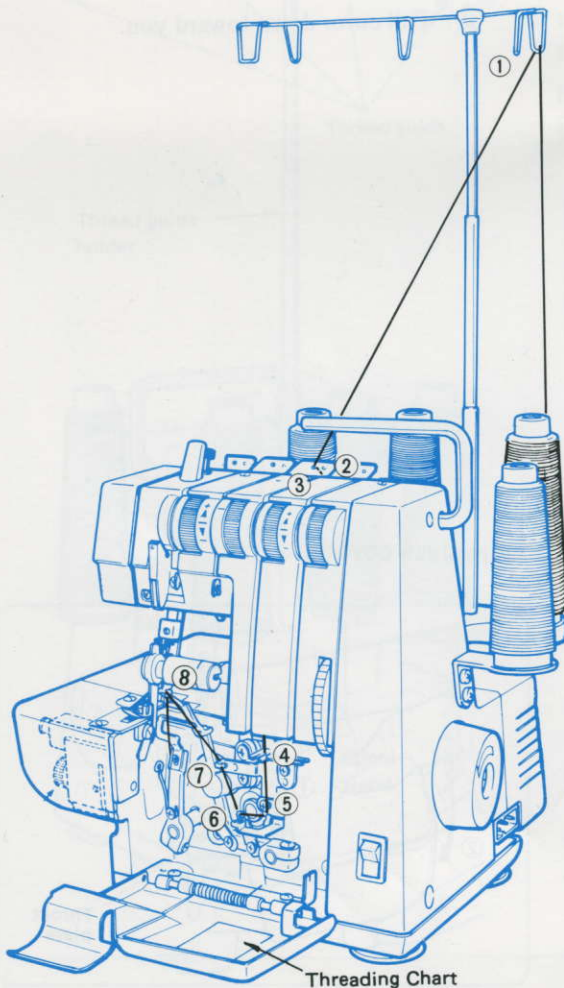

While holding thread with finger, pass it between the tension discs and pull thread down to make certain it is properly located in between the tension discs.

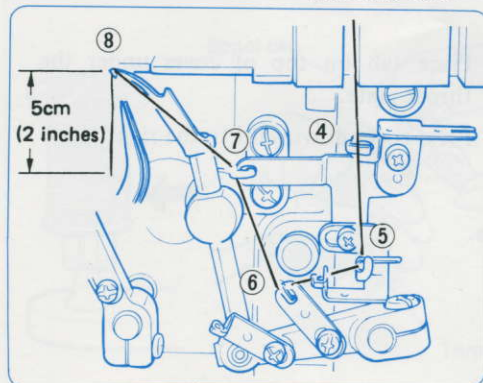

- Use tweezers provided in the accessory set when threading looper thread hole ⑧ .
- Draw about 5cm (2 inches) of thread from the looper thread hole.

- (2) Thread left looper in sequence from **a** to **i** (marked in yellow color). Cylinder cover must also be removed when threading this part. (Refer to page 5 for cylinder cover removal).

While holding thread with finger, pass it between the tension discs and pull thread down to make certain it is properly located in between the tension discs.

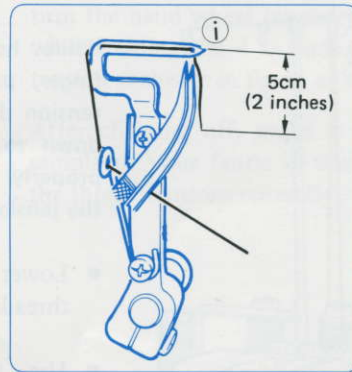
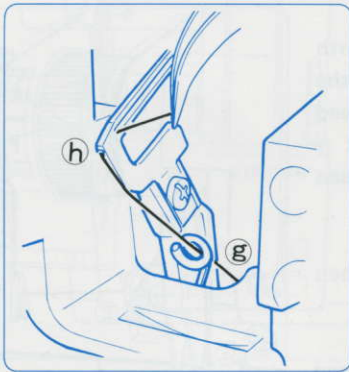
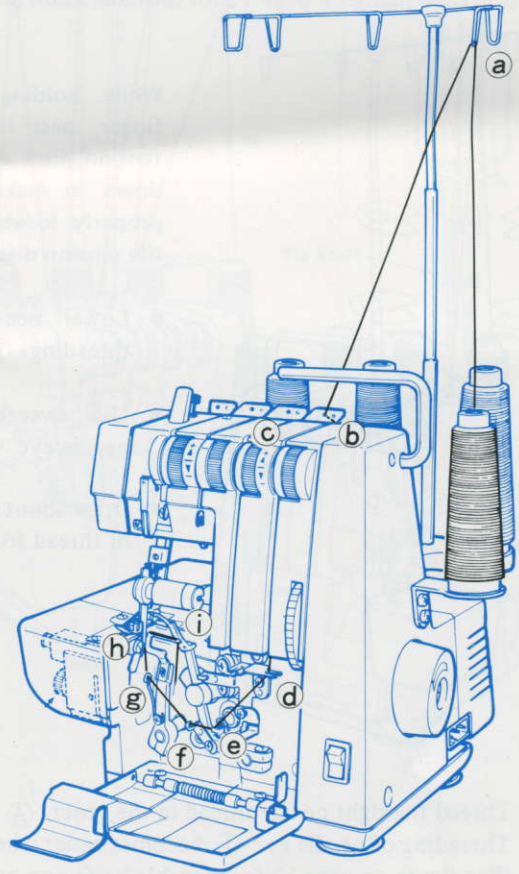
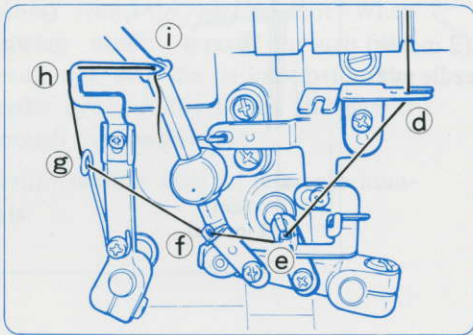

Turn hand wheel toward you until left looper is at left as far as it will go and thread looper thread hole **h** from left to right. (Use tweezers provided in your accessory set).

Turn hand wheel toward you until the looper is at right as far as it will go passing the thread under the throat plate, then using the tweezers, thread the looper thread hole **i** from front to back. Draw about 5cm (2 inches) of thread from thread hole.

- (3) Thread the left needle thread in the order (A) to (H) (blue mark).
Threading of needle eye (H) becomes easier when the movable knife is set at the non-operating position (See figure on page 12 for movable knife non-operating position).

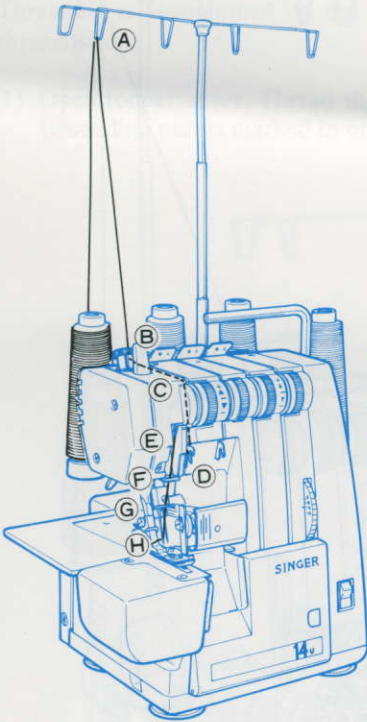

While holding thread with finger, pass it between the tension discs and pull thread down to make certain it is properly located in between the tension discs.

- Lower needle bar when threading (E) and (F).
- Use tweezers to thread needle eye (H).
- Draw about 5cm (2 inches) of thread from needle eye.

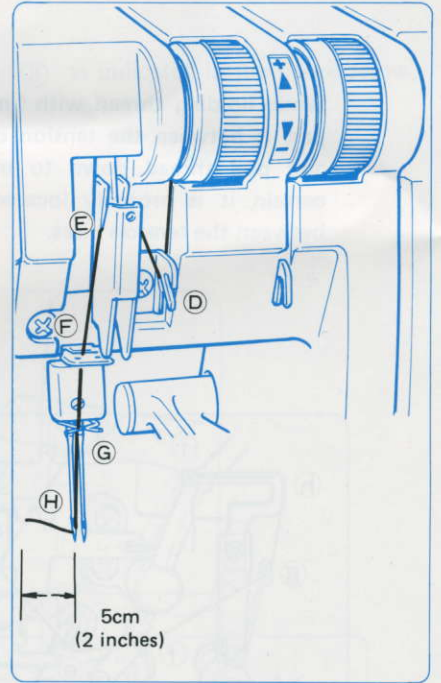

- (4) Thread the right needle thread in the order (A) to (I) (green mark).
Threading of needle eye (I) becomes easier when the movable knife is set at the non-operating position (See figure on page 12 for movable knife non-operating position).

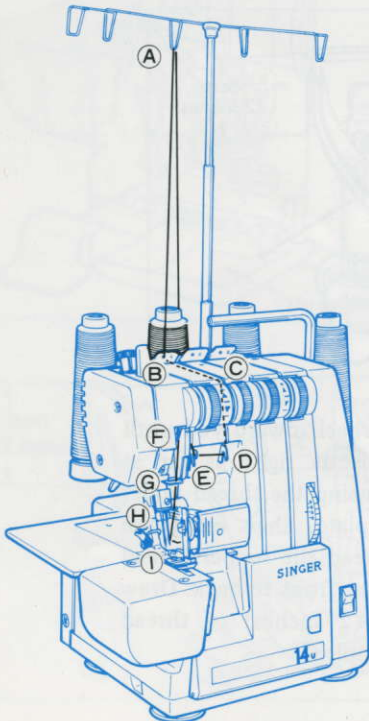

While holding thread with finger, pass it between the tension discs and pull thread down to make certain it is properly located in between the tension discs.

- Lower needle bar when threading (F) and (G).
- Use tweezers to thread needle eye (I).
- Draw about 5cm (2 inches) of thread from needle eye.

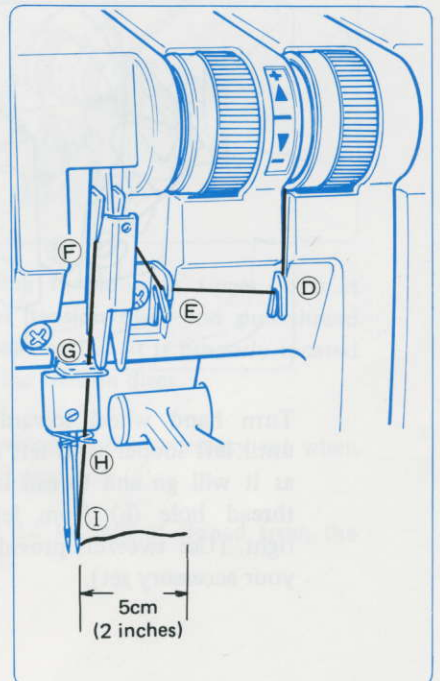

• How to change threads

When you wish to change the left needle thread, right needle thread, left looper thread or right looper thread with a different thread, the following steps will make the changing convenient.

- (1) Cut the thread near the spool and tie the end to the thread you wish to change to as shown in figure at right.
- (2) Raise presser foot.
- (3) Note tension reference numbers.
- (4) Turn the tension dials down toward the (-) mark until the dial stops and draw the thread out so that the tie knot of the threads extend about 5cm (2 inches) from the presser foot. When drawing needle thread through the needle eye, stop the tie knot before the needle eye, cut the thread and pass it through the needle eye.
- (5) Return tension dials to reference numbers.

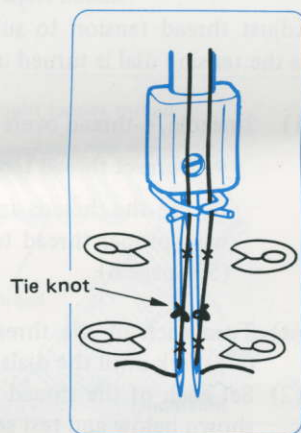
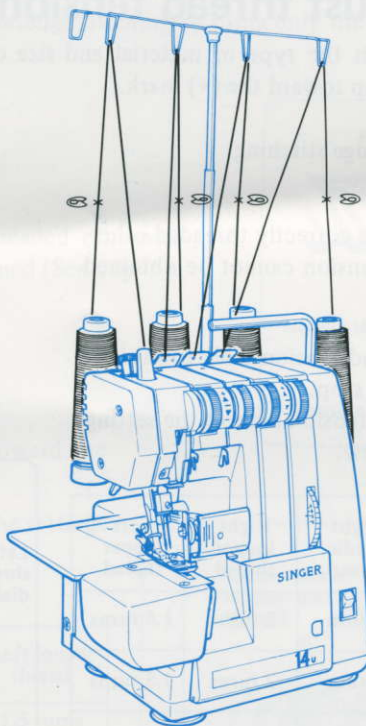

4. Chain off and test sew

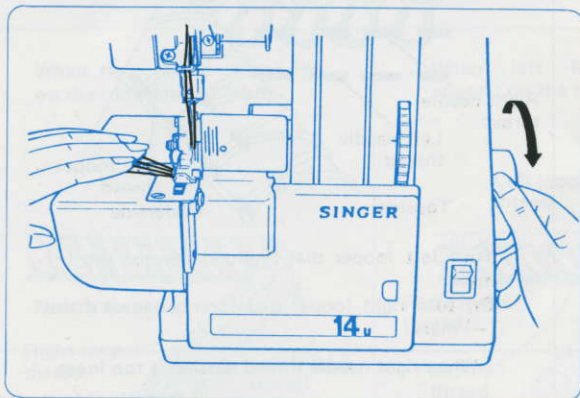

When the machine is completely threaded, turn the hand wheel toward you 2 or 3 turns while holding the 4 threads applying a slight tension as shown in figure at left.

After chaining off, make a test stitch on a sample of your fabric so that you can adjust the thread tensions correctly.

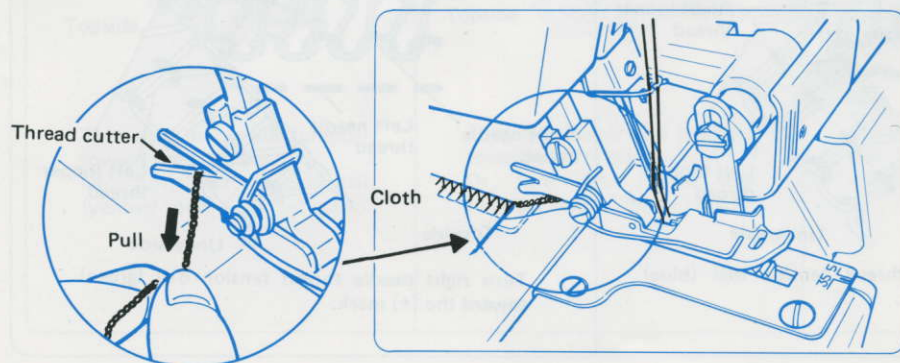

After completing the seam, chain off approx. 5cm (2 inches) as shown in figure at left and cut thread with the thread cutter on the presser foot.

5. How to adjust thread tension

Adjust thread tension to suit the type of material and size of the thread used. Tension becomes tighter as the tension dial is turned up toward the (+) mark.

1) 2-needle, 4-thread overedge stitching

• Correct thread tension

Be use the threads are correctly threaded otherwise proper thread tension cannot be obtained (See page 6).

- (1) Turn each of the thread tension dials toward the (-) mark until the dials stop.
- (2) Set each of the thread tension dials to the settings shown below and test sew.

Thread tension	Left needle thread	Right needle thread	Right looper thread	Left looper thread
Light weight	1 turn	1 turn	2 turns	1.5 turns
Medium weight	1.5 turns	1 turn	2 turns	1.5 turns
Heavy weight	2 turns	1.5 turns	2.5 turns	2 turns

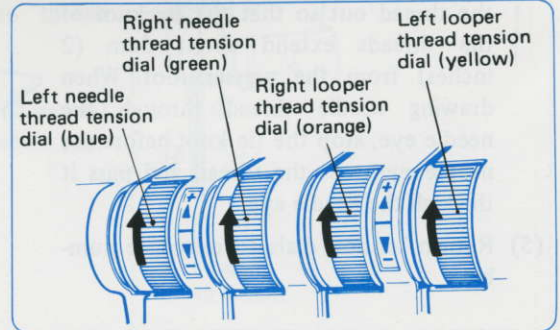
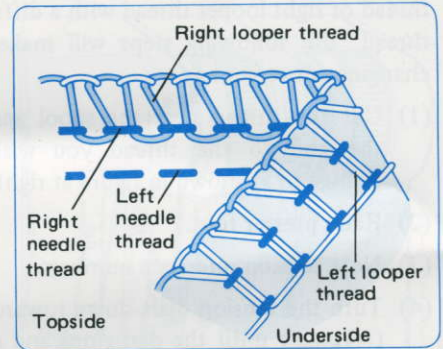

With following figure as reference, adjust the thread tension dials to obtain correct tension.

When right looper thread lies on the underside of fabric.

Turn right looper dial (orange) toward the (+) mark. Or, turn left looper dial (yellow) toward the (-) mark.

When left looper thread appears on the top.

Turn left looper dial (yellow) toward the (+) mark. Or, turn right looper dial (orange) toward the (-) mark.

When left needle thread tension is too loose.

Turn left needle thread tension dial (blue) toward the (+) mark.

When right needle thread tension is too loose.

Turn right needle thread tension dial (green) toward the (+) mark.

CONTENTS

	Page
1. Principal parts	2
2. Preparation prior to sewing	3
3. Threading the machine	4
• Setting up the thread guide holder	4
• How to open looper cover	5
• How to remove cylinder cover	5
• How to thread your machine correctly	6
• How to change threads	9
4. Chain off and test sew	9
5. How to adjust thread tension	10
6. How to adjust stitch length	12
7. How to adjust overedge seam width	12
8. How to roll hem	13
9. Free arm sewing (tubular work)	15
10. Seam guide lines	15
11. Edge guide	16
12. Variation stitch	16
• Ornamental stitching	16
• Blindstitching	18
• Braiding by chaining-off	18
• Pin tucking	19
• Reinforced (tapes) overedge stitching	19
• Turning square corners	20
13. How to replace needles	21
14. How to replace stationary knife	21
15. How to exchange light bulb	21
16. How to adjust presser foot pressure	22
17. Lubrication	22
18. Reasons for poor stitches and how to make adjustment	23
19. Relationship between cloth, thread and needle	24
20. Accessories	25
21. Specification	25